

SUNFRAME®

A Stunning Environmental Statement



Ground Mounted
Solution



Open Structure
Solution

Kyocera's award-winning
Solar Grove carport
© 2007, courtesy of Kyocera Solar Inc.

Unirac's SunFrame system leads the PV market with its superior aesthetics. Its sleek design is engineered to sit low to the roof without gaps and implements shared rails for the best value.

Low and clean lines give SunFrame two advantages. The finished array stands off the roof just enough for cooling air flow to optimize module performance while all modules sit in low, gap-free rows without protrusions from the sides of the array.

SunFrame is also the choice of solar experts as the optimal solution for custom carport structures. It's accompanied by a technical support system that provides complete installation and code compliance documentation, an on-line estimator and design assistance to help you solve the toughest challenges.

 **UNIRAC**®
Bright Thinking in Solar

Visit us online at www.unirac.com

SUNFRAME SHARED RAIL

PV's most versatile mounting system

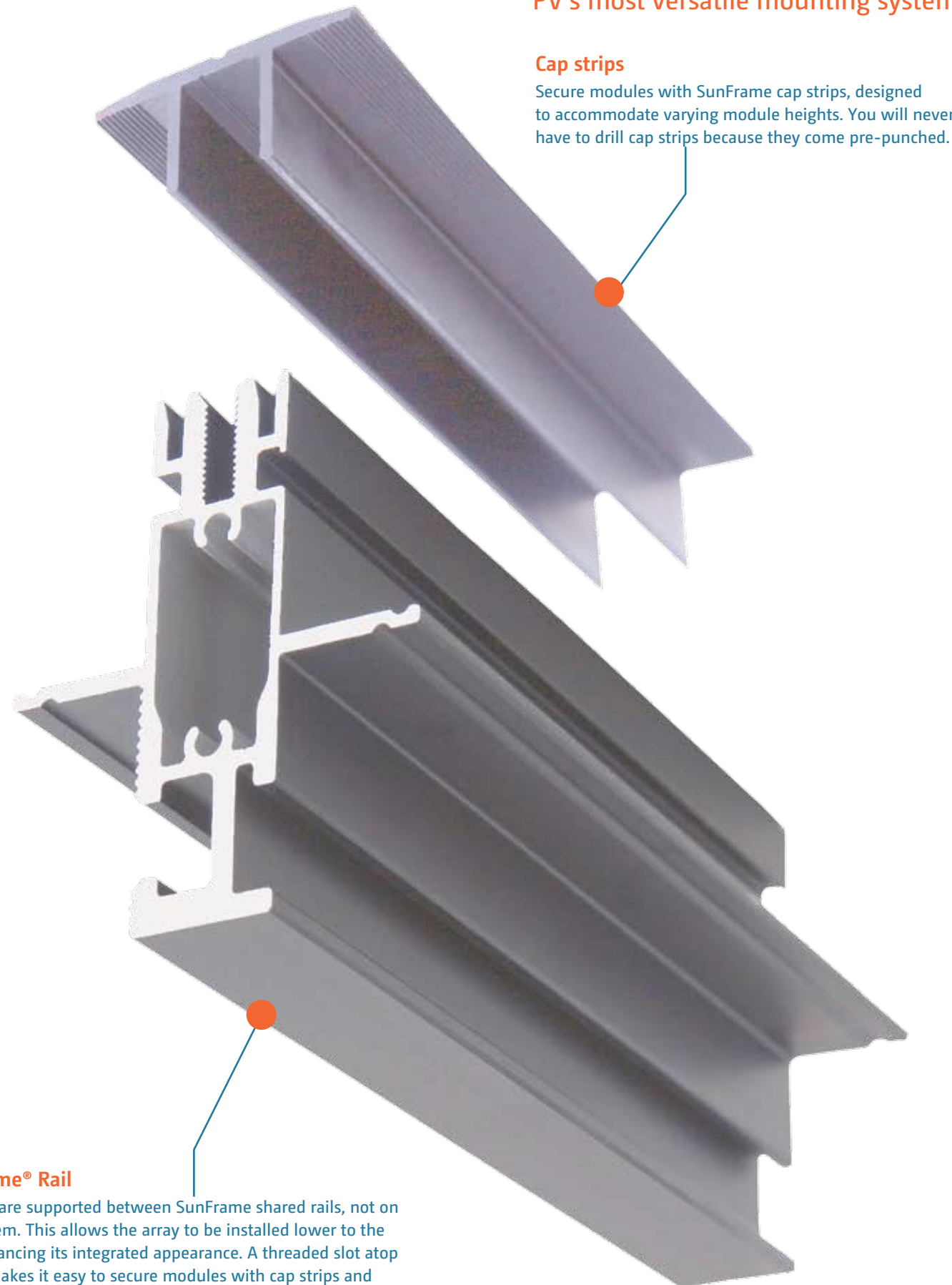

Cap strips

Secure modules with SunFrame cap strips, designed to accommodate varying module heights. You will never have to drill cap strips because they come pre-punched.

SunFrame® Rail

Modules are supported between SunFrame shared rails, not on top of them. This allows the array to be installed lower to the roof, enhancing its integrated appearance. A threaded slot atop the rail makes it easy to secure modules with cap strips and should it ever become necessary, replace modules easily.

SUNFRAME SHARED RAIL

PV's most versatile mounting system

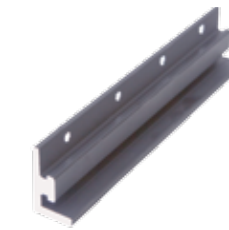

Splices

Hidden splices are used to create long rows of modules. If required, install them to allow thermal expansion. Consult SunFrame installation instructions for details on thermal expansion.



Standoffs & Flashings

Two-piece standoffs speed installation on tile roofs. We offer six flashing choices for our aluminum or steel standoffs which can be precisely placed over the secured base of a stand-off prior to the installation of the standoff itself.



L-Feet

Serrated L-feet attach directly to asphalt shingle roofs or rest on adjusting sliders or standoffs.



L-Foot adjusting sliders

L-feet can be easily adjusted along fixed sliders to ensure rails fit snugly against modules.



End caps.

UV resistant black end caps hide the rail end extrusion completing your installation.

KEY BENEFITS

of SunFrame Rail System

Superior aesthetics

- Modules are flush mounted in low-gap-free rows
- Visible components match clear or dark module frames
- End caps cover rail cross-section
- Optimized module performance, system spacing allows convection cooling

Ease of installation

- Installer-friendly components
- Minimized penetration with longer attachment spans than competitive products
- Designed with customer input

Complete technical support

- Installation and code compliance documentation
- Downloadable estimator
- Person-to-person customer service

Bright Thinking in Solar



Code Compliant

The SunFrame® system is PE certified. Call Unirac for documentation applicable to your building code.

Warranty

SunFrame® is covered by a 10-year limited product warranty and a 5-year limited finish warranty.

For complete warranties, download any SunFrame® installation manual from our web site.

Component Specifications

6105-T5 aluminum extrusion

- SunFrame® rails
- Cap strips
- Splices
- two-piece standoffs
- L-foot
- L-foot sliders

UV resistant plastic

- End caps

Severe Condition 4 (very severe)
zinc-plated welded steel

- End caps

304 stainless steel

- Fasteners



Visit us online at www.unirac.com